

3.8 Pipe Inlet Sediment Trap

(Source: Modified from City of Plano BMP SP-11)

Sediment Control

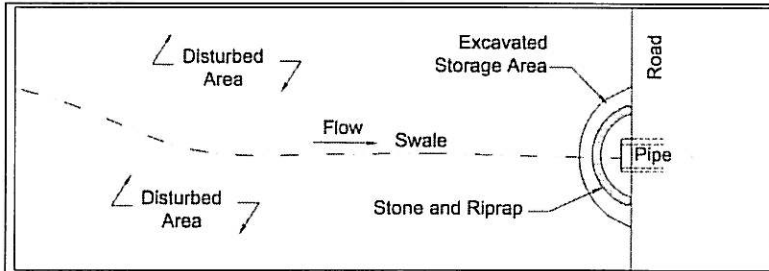

Description: The pipe inlet sediment trap is a barrier surrounding a pipe inlet to capture sediment before it enters a closed drainage system. The barrier may be made of concrete block and filter stone or stone riprap and filter stone. The barrier provides both filtration and detention for sediment to settle in the excavated area.

KEY CONSIDERATIONS

DESIGN CRITERIA:

- Top of control shall be no higher than half the pipe diameter
- Excavate a storage volume for the 2-year, 24-hour design storm upslope of the barrier
- Side slopes of 2:1 or flatter on the excavated storage area
- Maximum drainage area of 5 acres
- Overflow capability required for large storm events

ADVANTAGES / BENEFITS:

- Removes sediment before it enters a closed conveyance system

DISADVANTAGES / LIMITATIONS:

- Ponding upstream of the pipe inlet with localized flooding possible
- Type A Pipe Inlet Sediment Trap limited to pipes of 36 inches in diameter or less

MAINTENANCE REQUIREMENTS:

- Inspect regularly
- Remove trash and debris after each storm event
- Remove sediment from the sediment storage area before it reaches half the design depth
- If de-watering of the storage volume is not occurring, clean or replace the filter stone

TARGETED POLLUTANTS

- Sediment
- Nutrients & Toxic Materials
- Oil & Grease
- Floatable Materials
- Other Construction Wastes

APPLICATIONS

Perimeter Control

Slope Protection

Sediment Barrier

Channel Protection

Temporary Stabilization

Final Stabilization

Waste Management

Housekeeping Practices

Fe=0.50-0.75

(Depends on soil type)

IMPLEMENTATION CONSIDERATIONS

- Capital Costs
- Maintenance
- Training
- Suitability for Slopes > 5%

Other Considerations:

- *Re-grading and stabilization of the control area after construction*

3.8.1 Primary Use

The pipe inlet sediment trap is used to intercept and filter sediment from concentrated flows at the inlet to a pipe. Capturing sediment before it enters a closed conveyance system decreases the cost of cleaning and removing sediment from the system.

3.8.2 Applications

The pipe inlet sediment trap should be used where existing or proposed storm drain pipes or culverts are used prior to final stabilization of the area draining to the pipe inlet.

3.8.3 Design Criteria

- The pipe inlet sediment trap must be designed with overflow capability, since this control is used where pipe culverts collect relatively heavy concentrations of stormwater flows.
- The drainage area contributing runoff to the sediment trap shall be not larger than 5 acres.
- Type A pipe inlet sediment trap is limited to pipes of 36 inches diameter and smaller. Type B pipe inlet sediment trap should be used on larger pipes.
- A stormwater and sediment storage area shall be excavated upslope of the stone barrier. Minimum storage area volume should be the volume of runoff from the temporary control design storm (2-year, 24-hour). Caution should be exercised during excavation so as to not undermine the control structure or the pipe that is being protected.
- Side slopes surrounding the storage area shall be 2:1 or flatter.
- Top of stone and sediment storage created by the stone shall not be any higher than half of the inlet pipe diameter. On Type A Pipe Inlet Sediment Trap, the concrete blocks shall not be stacked any higher than two blocks high.
- Concrete blocks shall be standard 8"x8"x16" concrete masonry units and shall be in accordance with ASTM C139, Concrete Masonry Units for Construction.
- Wire fabric shall be a standard galvanized hardware fabric with ½ inch by ½ inch openings.
- Filter stone shall be nominal 1½ inch washed stone with no fines. Angular shaped stone is preferable to rounded shapes.
- Stone riprap shall be 6 inch to 12 inch well-graded stone, Dry Riprap, Type A.
- Riprap shall be placed on filter fabric meeting the following minimum criteria:
 - Tensile Strength, ASTM D4632 Test Method for Grab Breaking Load and Elongation of Geotextiles, 250-lbs.
 - Puncture Rating, ASTM D4833 Test Method for Index Puncture Resistance of Geotextiles, Geomembranes, and Related Products, 135-lbs.
 - Mullen Burst Rating, ASTM D3786 Standard Test Method for Hydraulic Bursting Strength of Textile Fabrics-Diaphragm Bursting Strength Tester Method, 420-psi.
 - Apparent Opening Size, ASTM D4751 Test Method for Determining Apparent Opening Size of a Geotextile, U.S. Sieve No. 20 (max).
- The pipe inlet sediment trap is most effective with coarse silt and sand soil particles. A passive treatment system may be used with the sediment trap to remove fine silt and clay soil particles.

3.8.4 *Design Guidance and Specifications*

Specifications for the riprap used in this item may be found in the Standard Specifications for Public Works Construction – North Central Texas Council of Governments, Section 803.3 Riprap.

3.8.5 *Inspection and Maintenance Requirements*

The pipe inlet sediment trap should be inspected regularly (at least as often as required by the TPDES Construction General Permit) to ensure that the device is functioning properly. The controls should also be checked after storm events to verify it's operating properly and to inspect for damages. Make repairs as needed.

Trash and debris should be removed from the trap after each storm event to prevent it from plugging the rock. Remove sediment from the storage area before the depth of sediment is half of the design depth. If the sediment storage area is not being de-watered, the filter stone surrounding the pipe inlet must be cleaned or replaced. Cleaning the filter stone surface the first few times by raking may be adequate. Repeated sediment build-up and clogging of the stone will require filter stone removal and replacement.

3.8.6 *Example Schematics*

The following schematics are example applications of the construction control. They are intended to assist in understanding the control's design and function.

The schematics are **not for construction**. They may serve as a starting point for creating a construction detail, but they must be site adapted by the designer. In addition, dimensions and notes appropriate for the application must be added by the designer.

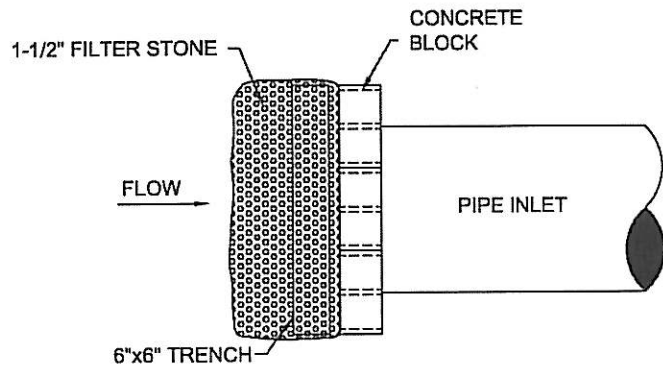

TYPE A PIPE INLET SEDIMENT TRAP PLAN VIEW
N.T.S.

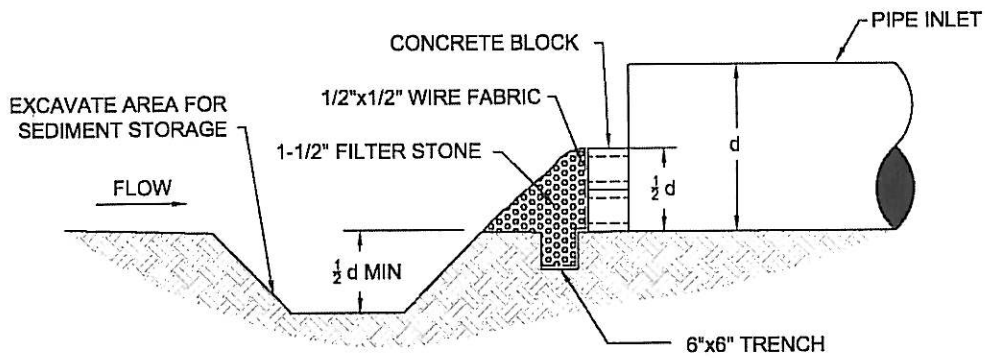

TYPE A PIPE INLET SEDIMENT TRAP CROSS SECTION
N.T.S.

NOTE: THE TYPE A CONTROL IS FOR USE ON PIPES WITH A DIAMETER EQUAL TO OR LESS THAN 36 INCHES.

Figure 3.17 Schematics of Type A Pipe Inlet Sediment Trap
(Source: Modified from City of Plano BMP SP-11)

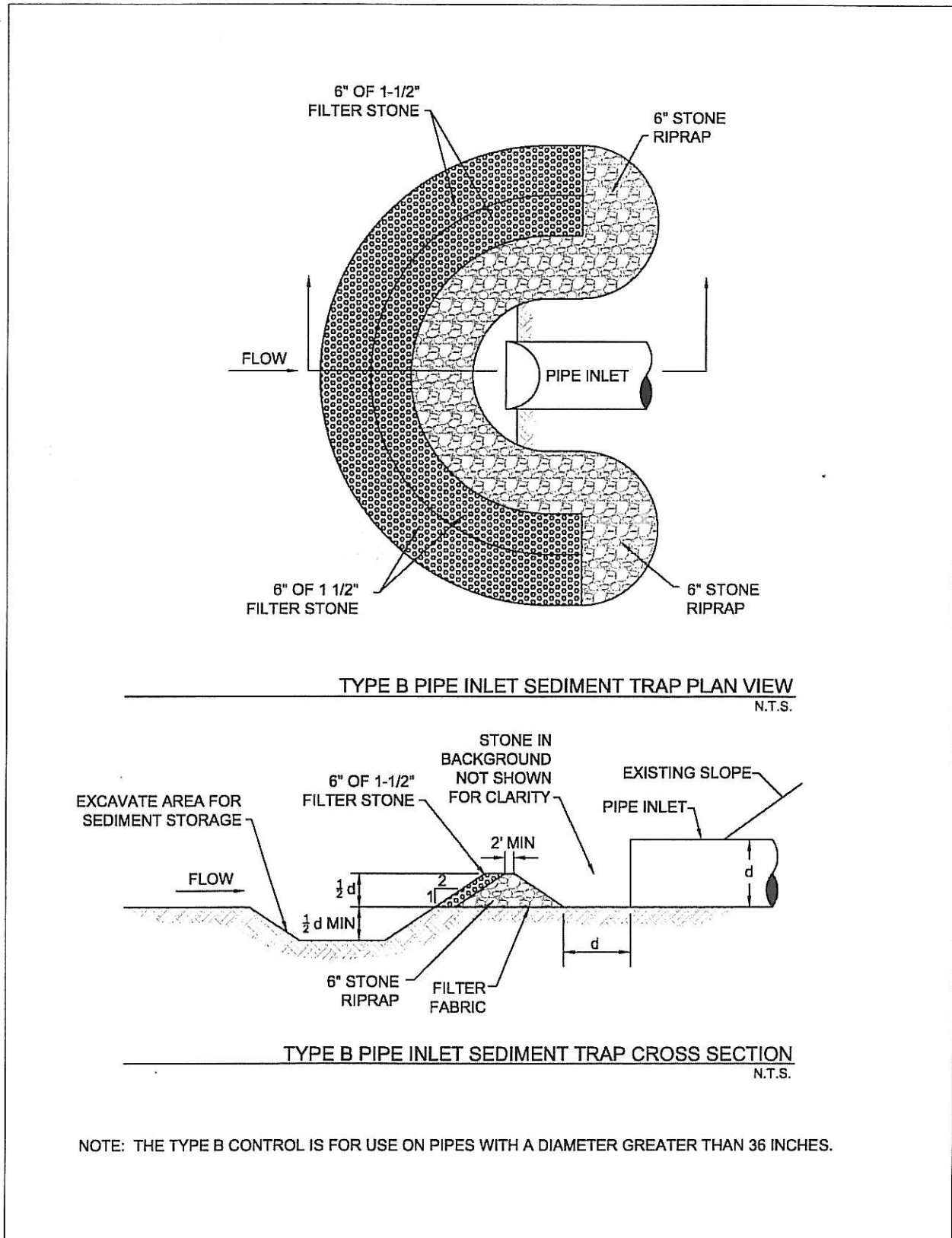

Figure 3.18 Schematics of Type B Pipe Inlet Sediment Trap
 (Source: Modified from City of Plano BMP SP-11)